

# Material Handling Solutions by **Omega Lift** Manufacturing Inc.



## 2X Series



### STANDARD EQUIPMENT

#### Engine

- Perkins diesel engine
- EPA Compliant
- Block heater with extension cord
- Glow Plugs

#### Transmission

- Power shift transmission—  
3 speeds forward / 3 reverse
- Electric column shifter with  
torque converter
- Transmission disconnect on  
park brake
- Transmission oil cooler

#### Axles/Brakes

- Planetary 2-wheel drive
- 2-wheel power steering
- Enclosed, wet disc brakes (front axle)
- Oscillating rear axle
- Hydraulic powered brakes  
with accumulator
- Internal spring applied hydraulic  
release park brake

#### Operator Compartment

- Open FOPS
- Tilt/telescopic molded steering  
column including full gauge  
cluster and back lighting

- Low profile mechanical suspension  
seat with lumbar adjustment and  
retractable seatbelt
- Grab handles and cab step
- 2 speed fan
- Roof glass

#### Instrumentation

- Full gauge cluster including; fuel  
level, water temperature, engine  
oil pressure, AMP meter.
- Indicator lights including; low  
battery, low oil pressure, high  
water temperature, high  
transmission oil temperature,  
glow plugs, park brake

#### Mast/Carriage

- I-beam roller mast
- Mast side shift
- Clear View design
- Premium mast chain
- Hardened chain pulleys
- Sealed, maintenance free  
roller bearings
- Shaft Carriage
- Shaft Forks

#### Electrical

- 12 V negative ground system

- Labeled fuses with holder
- 970 CCA battery
- 65 AMP alternator

#### Additional Features

- Solid steel frame
- Steel hydraulic and fuel tanks
- Chrome exhaust stack
- Lockable fuel, hydraulic, engine  
hood and battery compartment
- Front work lights
- Rear flashers
- 2-stage air cleaner
- Horn and back-up alarm
- Tire sealant

#### OPTIONAL EQUIPMENT

- Enclosed all-weather cab
- Air Conditioning
- AM/FM CD Sound System
- Lighting package
- Mirror package
- Low profile air suspension seat
- Washer system
- Planetary 4-wheel drive
- Foam-filled tires
- Customizable mast, carriage and forks
- Anti-theft device
- Lock differential (front axle)
- Fork Positioning



1.866.724.6922 | [www.omegalift.net](http://www.omegalift.net)

# 2X Series

**6,000 lbs - 12,000 lbs load capacity**

**14'-30' lift height**

Built to the same tough standards as all Omega Lift machines, the **2X Series** is available in 2- or 4-wheel drive and ranges in lift capacity from 6,000 to 12,000 lbs. This versatile 2-wheel steer forklift with various mast and carriage sizes handles yard, construction, or any other rough terrain application with ease.

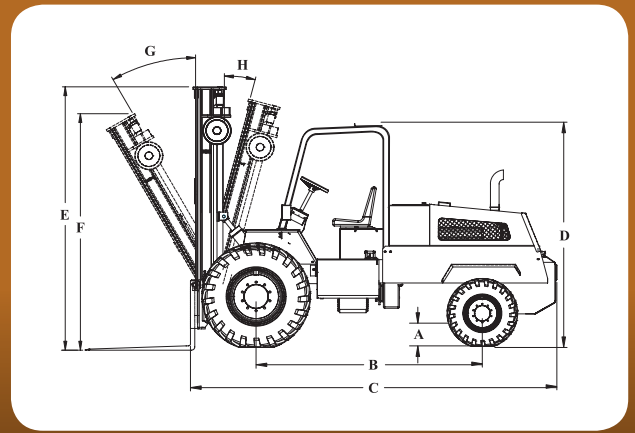

SPECIFICATION	Ref.	2X14-6	2X14-8	2X14-10	2X14-12
Lift Capacity @ 24" load centre (lbs)		6,000	8,000	10,000	12,000
Overall length (without forks)	C	162"	162"	162"	179"
Overall width		84"	84"	84"	84"
Wheelbase	B	84"	84"	84"	102"
Height to top of canopy	D	107"			
Closed height standard mast	E	134"			
Height standard full mast tilt	F	118"			
Maximum lift height (std mast)		14'			
Outside turning radius	B	173"	173"	173"	210"
Ground clearance	A	16"			
Mast clearance		11.5"			
Mast tilt - forward	G	30°			
Mast tilt - rear	H	15°			
Mast side shift - std.		+/- 3"			
Travel speed unladen - forward		17 mph			
Gradeability		40%			
Steering		2-wheel steer			
Drive (standard/optional)		2-wheel drive /4-wheel drive			
Tire size - front		15.5 x 25 - 12 ply			
Tire size - rear (2-wheel drive)		14 x 17.5 - 10 ply			
Tire size - rear (4-wheel drive)		14 x 17.5 - 14 ply			
Engine Manufacturer and model		Perkins 1104C-44 Natural Diesel			
Cylinders		4 Cylinders			
Horsepower		86 HP @ 2400 rpm			
Transmission		Powershift—3 speed forward / 3 reverse			
Shipping weight (lbs.)		15,300	16,800	18,150	19,600

Manufacturers specifications subject to change without notice