

Material Handling Solutions by **Omega Lift** Manufacturing Inc.



MEGA Series



STANDARD EQUIPMENT

Engine

- Perkins diesel engine
- EPA Compliant
- Block heater with extension cord
- Glow Plugs

Transmission

- Power shift transmission—
3 speeds forward / 3 reverse
- Limited slip differential (rear axle)
- Electric column shifter with
torque converter
- Transmission disconnect
on park brake
- Transmission oil cooler

Axles/Brakes

- Planetary 4-wheel drive
- 3 steering modes
(4-wheel, crab, 2-wheel)
- Enclosed, wet disc brakes
- Oscillating rear axle
- Hydraulic powered brakes
with accumulator
- Internal spring applied hydraulic
release park brake

Operator Compartment

- Open FOPS
- Full gauge cluster and indicator lights

- Low profile mechanical suspension
seat with lumbar adjustment and
retractable seat belt
- Grab handles and cab step
- 2 speed fan

Instrumentation

- Full gauge cluster including; fuel
level, water temperature, engine
oil pressure, AMP meter.
- Indicator lights including; low
battery, low oil pressure, high water
temperature, high transmission oil
temperature, park brake

Mast/Carriage

- I-beam roller bearing mast
- Clear View design
- Premium mast chain
- Hardened chain pulleys
- Sealed, maintenance free
roller bearings
- Shaft Carriage
- Shaft Forks

Electrical

- 12 V negative ground system
- Labeled fuses with holder
- 970 CCA battery
- 65 AMP alternator

Additional Features

- Solid steel frame construction
- Frame leveling
- Steel hydraulic and fuel tanks
- Chrome exhaust stack
- Lockable fuel, hydraulic, engine
hood and battery compartment
- Front work lights
- Rear flashers
- 2-stage air cleaner
- Horn and back-up alarm
- Tire sealant
- Tie down provisions

OPTIONAL EQUIPMENT

- Enclosed all-weather cab
- Air Conditioning
- AM/FM CD sound system
- Lighting package
- Mirror package
- Low profile air suspension seat
- Customizable mast, carriage and forks
- Mast side shift
- Lock differential (front axle)
- Fork positioning
- Light material bucket
- Grapple



1.866.724.6922 | www.omegalift.net

MEGA Series

8,000 lbs - 20,000 lbs load capacity

15'- 21' lift height

The powerful **MEGA Series** covers many applications from lumber and steel to general heavy lifting, and can handle loads up to 20,000 lbs. Capable of extended load centers, it features a strong frame and mast design to handle extra heavy loads. The MEGA Series is the solution for unique and heavy loads.

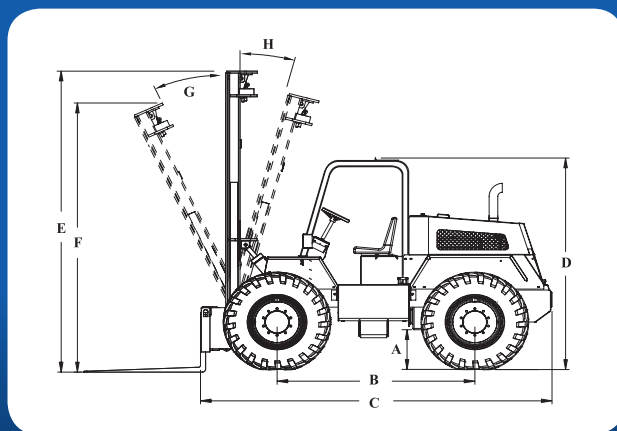

SPECIFICATION	Ref.	8MS	10MS	12MS	16MS	20MS
Lift Capacity @ 24" load centre (lbs)		8,000	10,000	12,000	16,000	20,000
Overall length (without forks)	C	165"	162"	179"	193.5"	210"
Overall width		99"				
Wheelbase	B	91"	91"	101"	115"	115"
Height to top of canopy	D	104"				
Closed height standard mast	E	140"				
Height standard full mast tilt	F	127"				
Maximum lift height (std mast)		15'	15'	15'	12'	12'
Outside turning radius		150"	150"	162"	172"	239"
Ground clearance	A	15"				
Drive		4-wheel drive				
Steering		4-wheel steer/2-wheel steer/ Crab Steer				
Mast clearance		11.5"	11.5"	11.5"	11.5"	10.5"
Mast tilt - forward	G	25°				
Mast tilt - rear	H	15°				
Mast side shift - optional		+/- 3"				
Travel speed unladen - forward		17 mph	17 mph	17 mph	20 mph	20 mph
Gradeability		40%				
Tire size		SGL D/L2A 15.5x25-12ply				SGL D/L2A 17.5x25- 16ply
Engine Manufacturer and model		Perkins 1104C-44T Turbo Diesel			Perkins 1104C-E44T Turbo Diesel	
Cylinders		4 Cylinders				
Horsepower		99 HP	99 HP	99 HP	115 HP	115 HP
Transmission		Powershift—3 speed-forward / 3 speed reverse				
Shipping weight (lbs.)		21,048	22,189	23,800	27,400	32,585

Manufacturers specifications subject to change without notice