



XF Series Diesel Pneumatic Tire Forklift

with capacities of 17,500 to 22,000lbs

The World of Hangcha



Simple/
Solid/
Smart



Comfortable Operation

In developing the XF 17500-22000lbs series, comfort and easy operation is always considered, for example, improved vibrating levels, compound engine damper and full floating seat and cabin are applied. Comfortable also contribute to increased productivity.

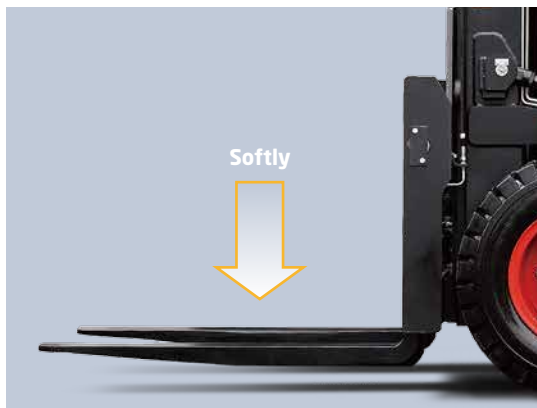

In addition to the soft landing system, the soft lifting system is adopted (front lifting cylinders of triplex mast and full free duplex mast), as a result, the noise and shock of the mast significantly decreases.



The extra foot space is provided to reduce operator fatigue significantly. The new wide-open, non-slip step makes getting in and out easy and safe.

The optional Electro-hydraulic proportional control system contributes more sensitive and precise load handling. The easy-to-operate levers provide total load handling operation. An armrest is provided to reduce fatigue.



The new design mast provides broad forward visibility due to outside located hydraulic pipes of fork positioner.



HANGCHA be with you at every stage

Efficient, reliable solutions for your demands

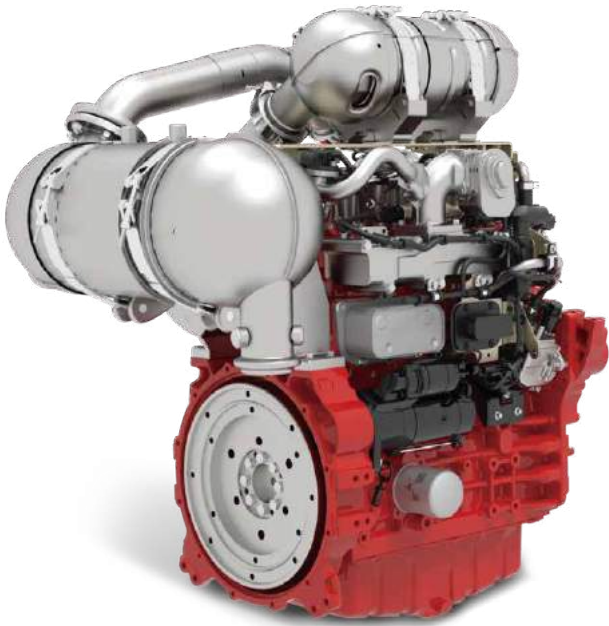

DEUTZ

TIER 4F

With Hangcha you can meet all Tier 4f emissions standards which provides customer demands for value, innovation and performance. The technologies include common rail fuel systems, diesel oxidation catalysts (DOC) and diesel particulate filters (DPF). Designed and optimised to every engine model, our forklift truck maximises efficiency and reliability.



The applied optimized exhaust muffler, intake muffler and the noise shield technologies are reduced 3dB at the driver's ear noise level.

Comfortable Operation

1. The new, relocated easy-to-see LCD meter lets the operator check on all aspects of operational status at a glance.
2. The new automobile-style light/turn-signal lever and forward-reverse lever are ergonomically designed and arranged to improve comfort and productivity.
3. Only 90N parking brake force is required.
4. The small diameter steering wheel with tilt adjustment provides the ideal operating position. The superior responsiveness of the steering wheel optimizes maneuverability even in narrow spaces.
5. The automobile-style suspended pedals provide more ergonomic operation.

Productivity

Thanks to the series technological innovations, the efficiency of the truck is improved, the energy consumption is reduced.



*By optimizing transmission design, the power train provides higher efficiency, and the Max. driving speed is increased **20%***



The new efficiency LED lighting system and new type reflector reduce energy consumption, improve illumination performance and prolong working life.

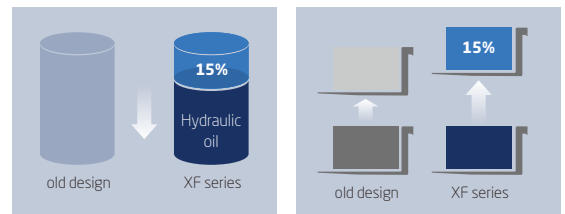

The new patent dynamic load sensing hydraulic steering system contributes to reduce loss of hydraulic, improve energy consumption and increase 15% lifting speed.

Reliability

By focusing on enhancing reliability, reducing downtime, the XF series is able to make the greater productivity for customer.

The patent plated-fin type aluminum radiator is applied, the heat exchanging is approved, and improves the capability for operation in severe environments.



There're four levels shock absorption applied to reduced the vibration from the road to the driver. The damping pad is applied reduce the vibration, Like between the steering axle and the chassis, The engine, torque convertor and the chassis, the overhead guard and the chassis. And the suspension seat is another vibration reduction.

High strength chassis, mast and front/rear axle are to make sure the reliability of the truck, even for high strength application.

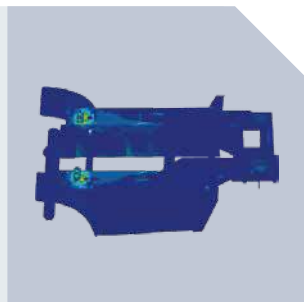

All the controllers, relays, and safety fuses are allocated in the controller box, free to water and dust. The main electronic components are waterproof, which is capable operator in severe environment.



The new stamped air cleaner featuring tangential intake, double seal with safety filter is durable, corrosion-free and vibration-resistant, provides better filter efficiency and lower intake resistance than the previous.



The battery is located above the fuel tank, there's battery box and adiabatic plate between them to prolong the battery's working life.



Add return oil filter of gearbox and multi-valve, improving the cleanliness of transmission and hydraulic oil.

Easy Maintenance



Careful design facilitates inspection and servicing. Easy maintenance reduces the amount of downtime and helps to reduce cost also.

The location of the air-filter is easy to reach, and it's very easy to replace the filter.

Brake drum is installed outside of wheel hub, easy to remove and install when we replace the brake shoes.

All the locations of the engine oil level dipstick, filter of hydraulic, water separator are easy to reach, and very easy for engineer to check.

There's gas spring support for the front cover of radiator, and it can auto-open when the rear cover of radiator is opened.

Safety

A wide range of technologies are applied to ensure absolute safety for both the operator and those in the surrounding. Independent braking and steering circuit without interference.



There's an energy accumulator applied in the braking system, which means when the engine is shut down, it can also provide more than 4 times emergency brake.



The locking device of the engine hood damper and parking brake help add to safety.



1. OPS system incorporates lifting/tilting and traveling locking function. When the operator leaves the seat, the system automatically locks lifting/tilting and disables traveling to ensure safety.
2. A throttling device is adopted to avoid the mast being out of control even some pipes are broken.

Standards

Transmission	Steering	Chassiss	Control	Hydraulic
<ul style="list-style-type: none"> / Suspension transmission / Oil filter / Dipstick / Oil cooler / Non-asbesttos bake / Wet brake 	<ul style="list-style-type: none"> / Full hydraulic power steering / Smaller diameter steering wheel / Adjuster of steering wheel / Shock absorber of steering axle 	<ul style="list-style-type: none"> / Skidproof pedal / Rubber pedal / Engine hood spring 	<ul style="list-style-type: none"> / Power steering / Suspension pedal / Integrated combination switch / Parking brake 	<ul style="list-style-type: none"> / Dynamic load sending control valve / Hydraulic oil filter / Tilt cylinder self-lock valve / Hydraulic oil dipstick / Accumulator / Hydraulic oil radiator

Truck	Power	Electronics	Mast	
<ul style="list-style-type: none"> / Traction device / Hand grip / Standard seat / Floating overhead guard / Waterproof cover on the guard / Back view mirror / Air pneumatic tyres / Toolbox 	<ul style="list-style-type: none"> / Big capacity aluminum radiator / Whirlwind air cleaner / Safety filter / High-efficient intake muffler / High-efficient exhaust muffler / High-positioned exhaust system 	<ul style="list-style-type: none"> / LED headlamp / High-efficient LED rear lights / Service-free start battery / Combination controller / LCD display / Neutual switch / Hour meter / Fuel gauge / Water temperature gauge 	<ul style="list-style-type: none"> / Pre-heat indicator / Charging indicator / Engine fuel pressure warning / Oil temperature / Horn / Reversing buzzer / Air-filter with jam sensor / Emergency power off 	<ul style="list-style-type: none"> / Standard wide view duplex mast / Standard forks / Standard fork carriage / Mast speed limiting valve / Load safety valve / Mast down buffer device / Mast up buffer device / Side roller / Fork positioner

Options

Truck	Power	Hydraulic	Electronics	Mast
<ul style="list-style-type: none"> / Full cabin / Cabin heater / Front window / Super pneumatic tyre / Non-mark tyre(white/green) / Suspension seat / Fire extinguisher / Special given color / Boot for tilt cylinder / Counter weight net / OPS 	<ul style="list-style-type: none"> / Overhead exhaust system / Air pre-cleaner / Radiator screen / Fan protector 	<ul style="list-style-type: none"> / Auxiliary hydraulic valve / Electro-hydraulic / Proportional control system 	<ul style="list-style-type: none"> / Front working light / Rear working light / Warning lamp 	<ul style="list-style-type: none"> / Duplex wide view free-lift mast / Triplex wide view free-lift mast / Special forks / Wider fork carriage / Widerload back rest

Optional Attachments

- / Paper roll clamp
- / Rotating bale clamp
- / Load stabilizer
- / Multi-drum clamp
- / Bale clamp
- / Drum clamp
- / Dumping clamp
- / Crane arm
- / String Pole
- / Sideshifter
- / Rotating forks
- / Fork extensioner
- / Load release device
- / Carton clamp
- / Push-pull device
- / Bucket
- / Hook
- / Lengthened fork



17500/22000lbs XF series mast: (pneumatic)

Type	Model	Max.fork height	Overall height		Free lift Without backrest	Load distance, centre of drive axle to fork	Tilt range	Load capacity		
			Lowered	Extended Without backrest			FWD/BWD	Load capacity at 24inch		
								Double tire		
								8t	10t	
in	in	in	in	(°)	lb	lb				
Wide view Duplex mast	X80M250	98	96	146	7.8	28.1	6/12	17637	/	
	X80M270	106	100	154	7.8	28.1	6/12	17637	/	
	X80M300	118	106	166	7.8	28.1	6/12	17637	/	
	X80M330	130	112	178	7.8	28.1	6/12	17637	/	
	X80M350	138	116	185	7.8	28.1	6/12	17637	/	
	X80M360	142	118	189	7.8	28.1	6/12	17637	/	
	X80M400	157	126	205	7.8	28.1	6/12	17637	/	
	X80M430	169	134	217	7.8	28.1	6/6	17637	/	
	X80M450	177	138	225	7.8	28.1	6/6	17637	/	
	X80M480	189	144	237	7.8	28.1	6/6	17637	/	
	X80M500	197	148	244	7.8	28.1	6/6	17637	/	
	X80M550	217	159	265	7.8	28.1	3/6	16314	/	
	X80M600	236	169	285	7.8	28.1	3/6	15432	/	
	X80M650	256	181	307	7.8	28.1	3/6	12787	/	
	X100M250	98	102	160	7.8	28.6	6/12	/	22046	
	X100M270	106	106	168	7.8	28.6	6/12	/	22046	
	X100M300	118	112	179	7.8	28.6	6/12	/	22046	
	X100M330	130	118	191	7.8	28.6	6/12	/	22046	
	X100M350	138	122	199	7.8	28.6	6/12	/	22046	
	X100M360	142	124	203	7.8	28.6	6/12	/	22046	
	X100M400	157	132	219	7.8	28.6	6/12	/	22046	
	X100M430	169	140	231	7.8	28.6	6/6	/	22046	
	X100M450	177	144	238	7.8	28.6	6/6	/	22046	
	X100M480	189	150	250	7.8	28.6	6/6	/	22046	
	X100M500	197	154	258	7.8	28.6	6/6	/	22046	
	X100M550	217	165	278	7.8	28.6	3/6	/	19872	
	X100M600	236	175	297	7.8	28.6	3/6	/	17637	
	X100M650	256	187	317	7.8	28.6	3/6	/	14771	
	Full free duplex mast	X80U230	91	93	138	45	28.3	6/12	17637	/
		X80U250	98	96	146	49	28.3	6/12	17637	/
X80U270		106	100	154	53	28.3	6/12	17637	/	
X80U300		118	106	166	59	28.3	6/12	17637	/	
X80U330		130	112	177	65	28.3	6/12	17637	/	
X80U360		142	118	189	71	28.3	6/12	17637	/	
X80U400		157	126	205	79	28.3	6/12	17637	/	
X100U230		91	98	151	38	29.3	6/12	/	22046	
X100U250		98	102	159	42	29.3	6/12	/	22046	
X100U270		106	106	167	45	29.3	6/12	/	22046	
X100U300		118	112	179	51	29.3	6/12	/	22046	
X100U330		130	118	191	57	29.3	6/12	/	22046	
X100U360		142	124	203	63	29.3	6/12	/	22046	
X100U400		157	131	218	71	29.3	6/12	/	22046	
Full free triplex mast	X80N450	177	108	227	58	29.9	6/6	15432	/	
	X80N480	189	112	239	62	29.9	6/6	15432	/	
	X80N500	197	116	250	63	29.9	6/6	14330	/	
	X80N550	217	122	268	71	29.9	3/6	13448	/	
	X80N600	236	128	286	78	29.9	3/6	12346	/	
	X80N650	256	139	309	87	29.9	3/6	11023	/	
	X80N700	276	146	327	94	29.9	3/6	9259	/	
	X100N450	177	112	238	51	31.3	6/6	/	18739	
	X100N480	189	116	250	55	31.3	6/6	/	18739	
	X100N500	197	120	258	59	31.3	6/6	/	18078	
	X100N550	217	126	278	65	31.3	3/6	/	16976	
	X100N600	236	132	297	71	31.3	3/6	/	15432	
	X100N650	256	143	317	82	31.3	3/6	/	13669	
	X100N700	276	150	337	89	31.3	3/6	/	11464	

With sideshifter minus 1102lbs,with integral sideshifter minus 882lbs

XF series 17500/22000lbs forklift specification :

			HANGCHA GROUP CO.,LTD.		
			FD80G	FD100G	
Distinguishing mark	1.1	Manufacturer			
		HCFA Model			
	1.2	Manufacturer's type designation	CPCD80-XW75G	CPCD100-XW75G	
	1.3	Drive: electric (battery or mains), diesel, petrol, fuel gas	Diesel	Diesel	
	1.4	Operator type: hand, pedestrian, standing, seated, order-picker	Seated	Seated	
	1.5	Rated capacity/rated load	Q (lb)	17500	22000
	1.6	Load centre distance	c(in)	24	24
	1.8	Load distance, centre of drive axle to fork	x(in)	28	29
	1.9	Wheelbase	y(in)	102	110
Weight	2.1	Service weight	lb	26455	30423
	2.2	Axle loading, laden front/rear	lb	39639/4453	47432/5015
	2.3	Axle loading, unladen front/rear	lb	10626/15829	14175/16248
Tyres, chassis	3.1	Tyres: solid rubber, superelastic, pneumatic, polyurethane		pneumatic	pneumatic
	3.2	Tyre size, front		9.00-20-14PR	9.00-20-14PR
	3.3	Tyre size, rear		9.00-20-14PR	9.00-20-14PR
	3.5	Wheels, number front rear (x = driven wheels)		4x/2	4x/2
	3.6	Tread, front	b ₁₀ (in)	64.1	64.1
	3.7	Tread, rear	b ₁₁ (in)	66.9	66.9
	Dimensions	4.1	Tilt of mast/fork carriage forward/backward	$\alpha/\beta(^{\circ})$	6/12
4.2		Height, mast lowered	h ₁ (in)	106.3	112.2
4.3		Free lift	h ₂ (in)	7.9	7.9
4.4		Lift	h ₃ (in)	118	118
4.5		Height, mast extended	h ₄ (in)	165.2	178.9
4.7		Height of overhead guard	h ₆ (in)	101.6	101.6
4.8		Seat height	h ₇ (in)	59.3	59.3
4.12		Coupling height	h ₁₀ (in)	19.9	19.9
4.19		Overall length	l ₁ (in)	216	226
4.20		Length to face of forks	l ₂ (in)	157	167
4.21		Overall width	b ₁ (in)	85.2	85.2
4.22		Fork dimensions	s/e/l (in)	3.0x6.3x59.1	3.1x6.3x59.1
4.23		Fork carriage DIN 15173, class/type A, B		IV A	IV A
4.24		Fork-carriage width	b ₃ (in)	76.8	76.8
4.31		Ground clearance, laden, mast	m ₁ (in)	7.3	7.3
4.32		Ground clearance, centre of wheelbase	m ₂ (in)	13.3	13.3
4.34.1		Aisle width for pallets 1000 x 1200 crossways	Ast (in)	221.9	231.2
4.34.2		Aisle width for pallets 800 x 1200 lengthways	Ast (in)	229.7	239.1
4.35		Turning radius	Wa (in)	146.9	155.1
4.36		Internal turning radius	b ₁₃ (in)	53.1	55
Performance data	5.1	Travel speed, laden/unladen	mph	-/17.7	-/17.7
	5.2	Lift speed, laden/unladen	ft/min	76.8/-	62.4/-
	5.3	Lowering speed, laden/unladen	ft/min	89.6/-	89.6/-
	5.5	Drawbar pull,laden/unden	N---ibf	65000/45000	72000/49000
	5.7	Gradeability, laden/unladen	%	>20/-	>20/-
	5.10	Service brake		Wet brake	Wet brake
Combustion-engine	7.1	Engine manufacturer/type		Deutz TCD 3.6L4f	Deutz TCD 3.6L4f
		Engine standard		Tier 4F	Tier 4F
	7.2	Engine power according to DIN ISO 1585	HP	114	114
	7.3	Rated speed	r/min	2200	2200
	7.4	No. of cylinders/displacement	(-)/(in ³)	4/220	4/220
Addition data	10.1	Operating pressure for attachments	bar	195	195
	10.2	Oil volume for attachments	l/min	57	57
	10.8	Towing coupling,type DIN 15170		Pin	Pin

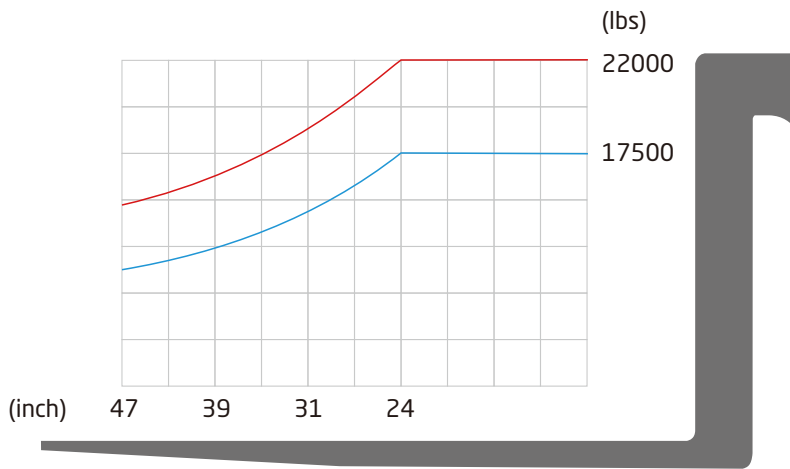
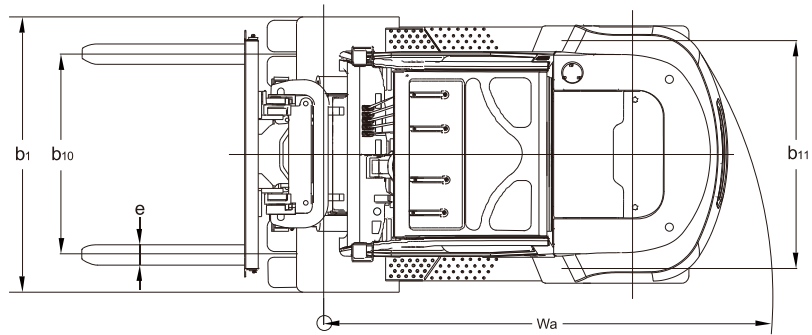
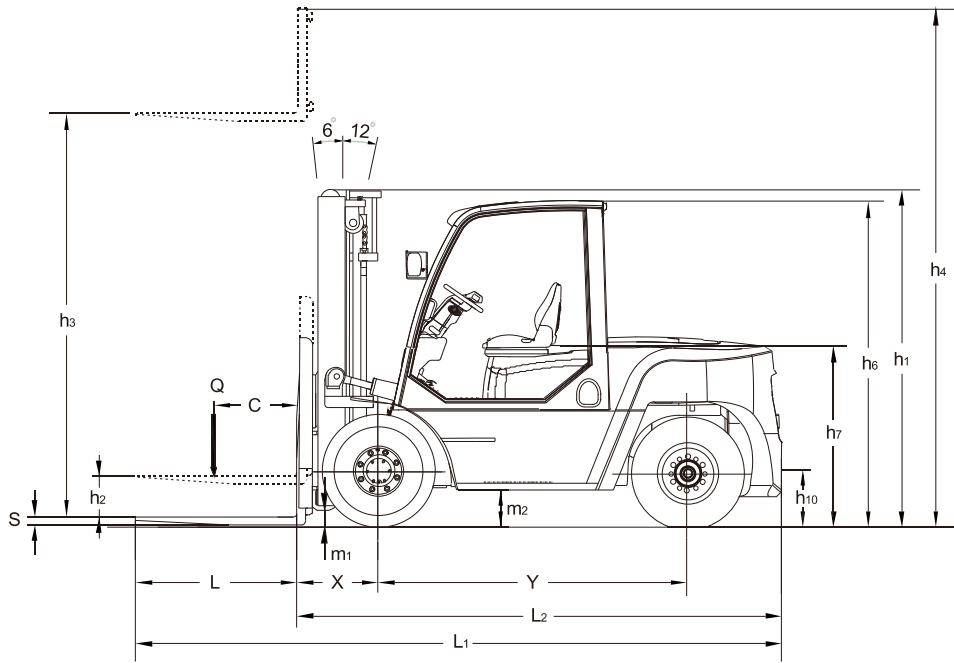



HC FORKLIFT AMERICA CORPORATION

Company address:
10405-A Granite Street Charlotte,
NC 28273

Toll Free: 888-652-8395
Phone: 980-888-8335
Fax: 980-888-8336

america@hcforklift.com
www.hcforkliftamerica.com



Follow us on
Facebook



Follow us on
YouTube



Follow us on
WeChat

HANGCHA GROUP CO., LTD. reserves the right to make any changes without notice concerning colors, equipment, or specifications detailed in this brochure, or to discontinue individual models. The colors of trucks, delivered may differ slightly from those in brochures.